



HYRUM CITY

83 West Main · Hyrum, Utah 84319
Phone (435) 245-6033

Construction Activity Permit Application

Applicant Name: _____ Phone: _____
Address: _____ City: _____
Responsible Person: _____ Phone: _____

1. Project Information

Original NOI Permit Number: _____
Parcel Number: _____ Lot: _____ Subdivision: _____
Site Address: _____

2. Submittal Requirements:

Residential

- Residential: Two (2) sets of plans, 11" x 17" minimum, plus narration
- Notice Of Intent issued by the Utah Division of Water Quality (www.waterquality.utah.gov/)

Commercial

- Commercial: Two (2) sets of plans, 18" x 24" minimum, plus narration
- Notice Of Intent issued by the Utah Division of Water Quality (www.waterquality.utah.gov/)

3. Please mark the following that pertain:

Project Type

- Single Family/Duplex/Townhome
- Multiple Family
- Remodel or Addition (Involving grading)
- Commercial Development
- Subdivision Development
- Demolitions:
 - Commercial
 - Residential
- Other: _____

Project Details

of Units _____ Approx. Acres _____
of Units _____ Approx. Acres _____
Approximate Acres _____
Acres Disturbed _____
Acres Disturbed _____
Acres Disturbed _____
Approximate Acres: _____

4. Please select Best Management Practices (BMPS) that will be used during the construction process and through final stabilization to ensure stormwater is adequately managed:

BMPS

- Benching
- Bioengineering
- Brush or Rock Filter
- Building Repair, Remodeling & Construction
- Catch Basin Cleaning
- Compaction
- Concrete Waste Management
- Construction Road Stabilization
- Dust Control
- Earth Berm Barrier
- Equipment & Vehicle Wash Down Area
- Geotextiles & Mats
- Inlet Protection – Concrete Block
- Inlet Protection - Excavated
- Inlet Protection – Gravel
- Inlet Protection – Silt Fence / Straw Bale
- Materials Storage
- Riprap
- Rock Check Dams
- Sand Bag Barrier
- Sediment Basin
- Sediment Trap
- Seeding and Planting
- Silt Fence
- Slope Drain
- Stabilized Construction Entrance
- Straw Bale Barrier
- Street Cleaning
- Temporary Stream Crossing
- Vehicle and Equipment Cleaning

Applicant Signature _____

Date _____

Hyrum City Office Use

Approved By: _____ Date: _____ City Permit # _____

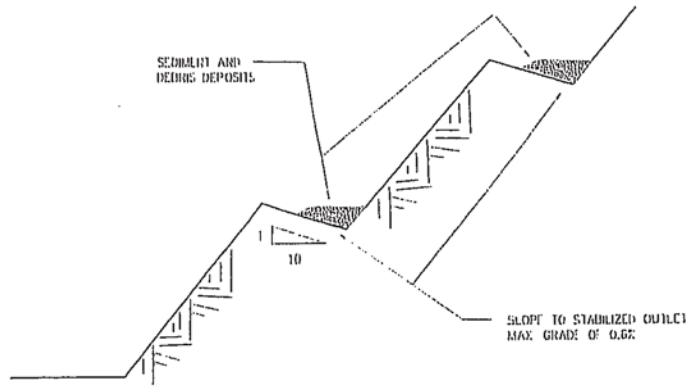

DESCRIPTION:

Slope construction with benches spaced at regular intervals perpendicular to the slope which intercept and collect sheet flow and direct it to a stable outfall point.

APPLICATION:

- ▶ Unstabilized cut and fill slopes
- ▶ Large stockpiles
- ▶ Existing unstable slopes

INSTALLATION/APPLICATION CRITERIA:

- ▶ Benches should be formed as slope is constructed and graded to the outlet point.
- ▶ Stabilized outlet with sediment controls should be in place prior to slope construction.

LIMITATIONS:

- ▶ Construction slope design must accommodate benching
- ▶ Not appropriate for sandy or rocky soil
- ▶ Only effective if suitable outlet provided

MAINTENANCE:

- ▶ Inspect after major storm events and at least biannually, repair any damaged areas
- ▶ Remove debris blocking water flow
- ▶ Inspect outlet, repair/replace sediment controls and remove sediment build up.

OBJECTIVES

- Housekeeping Practices
- Contain Waste
- Minimize Disturbed Areas
- Stabilize Disturbed Areas
- Protect Slopes/Channels
- Control Site Perimeter
- Control Internal Erosion



Developed by Salt Lake County

TARGETED POLLUTANTS

- Sediment
- Nutrients
- Toxic Materials
- Oil & Grease
- Floatable Materials
- Other Waste

- High Impact
- Medium Impact
- Low or Unknown Impact

IMPLEMENTATION REQUIREMENTS

- Capital Costs
- O&M Costs
- Maintenance
- Training

- High
- Medium
- Low

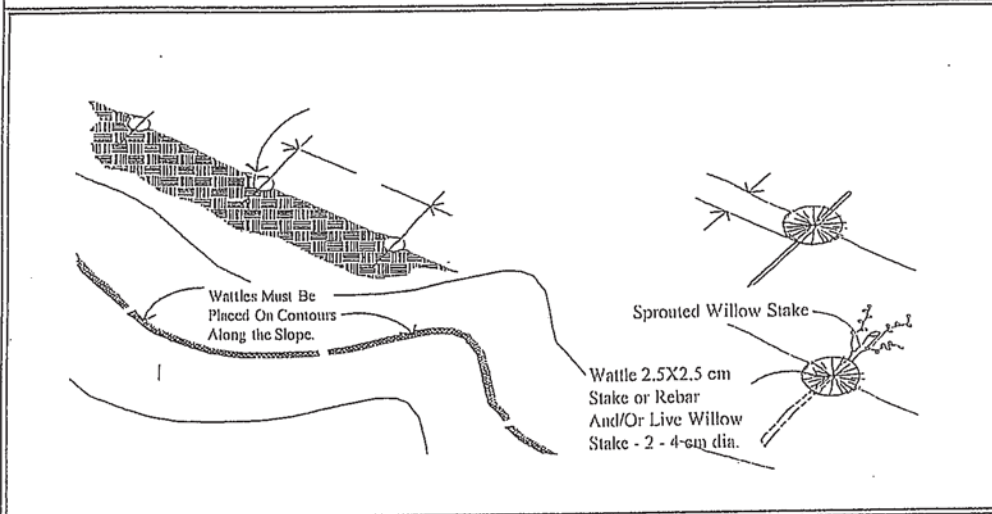

GENERAL DESCRIPTION:

Bioengineering methods combine vegetative and mechanical techniques to stabilize eroding slopes. Bioengineering methods include sprigging, tubeling, and wattling. Sprigging involves planting rhizomes, stolons, shoots, or sprouts of a desirable species. Tubelings are forbs, shrubs, or trees commercially available in reusable plastic tubes or sleeves. Wattles are bundles of cuttings from live willows, aiders, or similar plants placed and secured in trenches across a slope to aid in slope stabilization.

APPLICATIONS:

- ▶ Sprigging may be performed on cut and fill slopes or other areas needing permanent soil stability.
- ▶ Tubelings may be placed on any area needing revegetation, but are most useful on slopes or flat areas where poor topsoil conditions inhibit successful seed germination and early plant growth.
- ▶ Wattlings act to reduce slope length and aid in stabilizing slopes due to surface runoff, frost heaving, needle ice, or other soil movement.

INSTALLATION/APPLICATION CRITERIA:

- ▶ Sprigging involves tearing sod apart, planting rhizomes or stolons, or transplanting shoots or sprouts. Sprigs are placed by broadcast, punching-in or with a special sprig planter.
- ▶ Tubelings involve drilling holes to the depth necessary to accommodate roots.
- ▶ Wattles are best applied to slopes no steeper than 2:1.

LIMITATIONS:

- ▶ Availability of plant materials may affect what species can be used.
- ▶ May be necessary to arrange for commercially grown tubelings.
- ▶ Cannot be used as a substitute for retaining walls or similar devices to stabilize oversteepened slopes.

MAINTENANCE:

- ▶ Sprigging and tubeling plantings should be checked periodically until they are permanently established.
- ▶ Assess the need for replacement plantings or supplemental fertilizer.
- ▶ The wattlings should be inspected at regular intervals to make sure bundles are still secure and check for sprouting of the wattling material.

OBJECTIVES

- Housekeeping Practices
- Contain Waste
- Minimize Disturbed Areas
- Stabilize Disturbed Areas
- Protect Slopes/Channels
- Control Site Perimeter
- Control Internal Erosion



Developed by Salt Lake County

TARGETED POLLUTANTS

- Sediment
- Nutrients
- Toxic Materials
- Oil & Grease
- Floatable Materials
- Other Waste

- High Impact
- Medium Impact
- Low or Unknown Impact

IMPLEMENTATION REQUIREMENTS

- Capital Costs
- O&M Costs
- Maintenance
- Training

- High
- Medium
- Low

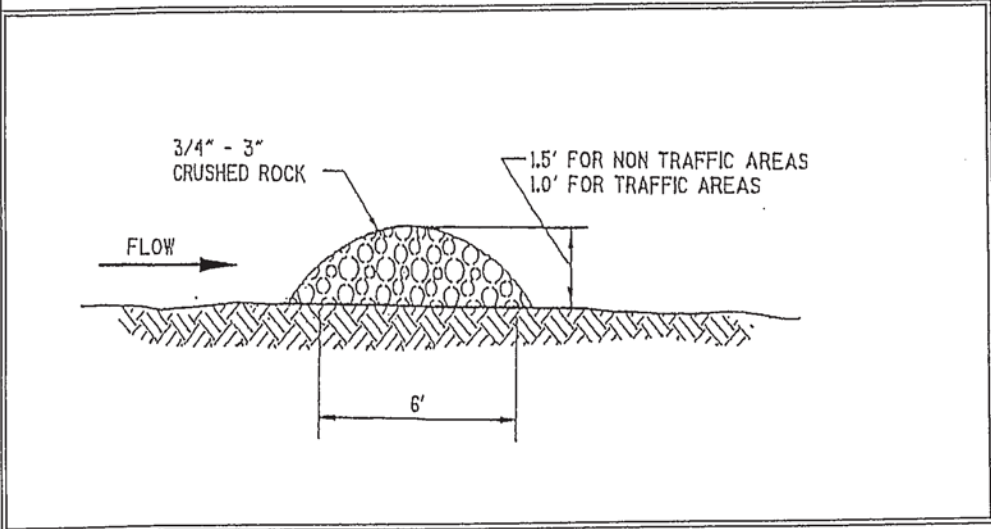

DESCRIPTION:

A rock filter is made of rock 3/4 - 3" in diameter and placed along a level contour. A brush filter is composed of brush (usually obtained during the site clearing) wrapped in filter cloth and anchored to the toe of the slope. If properly anchored brush or rock filters may be used for sediment trapping and velocity reduction.

APPLICATION:

- As check dams across mildly sloped construction roads.
- Below the toe of slopes.
- Along the site perimeter.
- In areas where sheet or rill flow occurs.
- Around temporary spoil areas.
- At sediment traps or culvert/pipe outlets.

INSTALLATION/APPLICATION CRITERIA:

- For rock filter, use larger rock and place in a staked, woven wire sheathing if placed where concentrated flows occur.
- Install along a level contour.
- Leave area behind berm where runoff can pond and sediment can settle.
- Drainage areas should not exceed 5 acres.

LIMITATIONS:

- Rock berms may be difficult to remove.
- Removal problems limit their usefulness in landscaped areas.
- Runoff will pond upstream of the filter, possibly causing flooding if sufficient space does not exist.

MAINTENANCE:

- Inspect monthly after each rainfall.
- If berm is damaged, reshape and replace lost/dislodged rock.
- Remove sediment when depth reaches 1/3 of berm height, or 1 ft.

OBJECTIVES

- Housekeeping Practices
- Contain Waste
- Minimize Disturbed Areas
- Stabilize Disturbed Areas
- Protect Slopes/Channels
- Control Site Perimeter
- Control Internal Erosion



Developed by Salt Lake County

TARGETED POLLUTANTS

- Sediment
- Nutrients
- Toxic Materials
- Oil & Grease
- Floatable Materials
- Other Waste

- High Impact
- Medium Impact
- IMPLEMENTATION REQUIREMENTS

- Capital Costs
- O&M Costs
- Maintenance
- Training

- High Medium Low

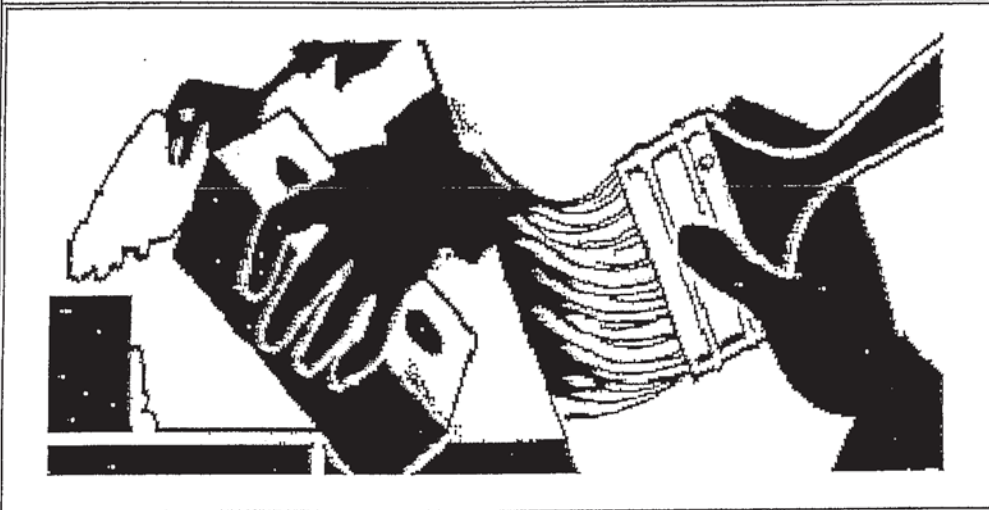

OBJECTIVES

- Housekeeping Practices
- Contain Waste
- Minimize Disturbed Areas
- Stabilize Disturbed Areas
- Protect Slopes/Channels
- Control Site Perimeter
- Control Internal Erosion



Developed by Salt Lake County

DESCRIPTION:

Prevent or reduce the discharge of pollutants to storm water from building repair, remodeling and construction by using soil erosion controls, enclosing or covering building material storage areas, using good housekeeping practices, using safer alternative products, and training employees.

APPLICATION:

- ▶ Use soil erosion control techniques if bare ground is temporarily exposed.
- ▶ Use permanent soil erosion control techniques if the remodeling clears buildings from an area that are not to be replaced.

INSTALLATION/APPLICATION CRITERIA:

- ▶ Enclose painting operations consistent with local air quality regulations and OSHA.
- ▶ Properly store materials that are normally used in repair and remodeling such as paints and solvents.
- ▶ Properly store and dispose waste materials generated from the activity.
- ▶ Maintain good housekeeping practices while work is underway.

LIMITATIONS:

- ▶ This BMP is for minor construction only.
- ▶ Hazardous waste that cannot be re-used or recycled must be disposed of by a licensed hazardous waste hauler.
- ▶ Safer alternative products may not be available, suitable, or effective in every case.
- ▶ Be certain that actions to help storm water quality are consistent with OSHA and air quality regulations.

MAINTENANCE:

None.

TARGETED POLLUTANTS

- Sediment
- Nutrients
- Toxic Materials
- Oil & Grease
- Floatable Materials
- Other Waste

- High Impact
- Medium Impact
- Low or Unknown Impact

- IMPLEMENTATION REQUIREMENTS
- Capital Costs
 - O&M Costs
 - Maintenance
 - Training

- High
- Medium
- Low



DESCRIPTION:

Maintain catch basin and stormwater inlets on a regular basis to remove pollutants, reduce high pollutant concentrations during the first flush of storms, prevent clogging of the downstream conveyance system, and restore the catch basins' sediment trapping capacity. A catch basin is distinguished from a stormwater inlet by having at its base a sediment sump designed to catch and retain sediments below the overflow point. This information sheet focuses on the cleaning of accumulated sediments from catch basins.

APPROACH:

Regular maintenance of catch basins and inlets is necessary to ensure their proper functioning. Clogged catch basins are not only useless but may act as a source of sediments and pollutants. In general, the key to effective catch basins are:

- ▶ At least annual inspections.
- ▶ Prioritize maintenance to clean catch basins and inlets in areas with the highest pollutant loading.
- ▶ Clean catch basins in high pollutant load areas just before the wet season to remove sediments and debris accumulated during the summer.
- ▶ Keep accurate logs of the number of catch basins cleaned.
- ▶ Record the amount of waste collected.

LIMITATIONS:

There are no major limitations to this best management practice.

MAINTENANCE:

Regular maintenance of public and private catch basins and inlets is necessary to ensure their proper functioning. Clogged catch basins are not only useless but may act as a source of sediments and pollutants. In general, the keys to effective catch basins are:

- ▶ Annual/monthly inspection of public and private facilities to ensure structural integrity, a clean sump, and a stenciling of catch basins and inlets.
- ▶ Keep logs of the number of catch basins cleaned.
- ▶ Record the amount of waste collected.

PROGRAM ELEMENTS

- New Development
- Residential
- Commercial Activities
- Industrial Activities
- Municipal Facilities
- Illegal Discharges



Developed by Salt Lake County

TARGETED POLLUTANTS

- Sediment
- Nutrients
- Heavy Metals
- Toxic Materials
- Oxygen Demanding Substances
- Oil & Grease
- Floatable Materials
- Bacteria & Viruses

- High Impact
- Medium Impact
- Low or Unknown Impact

IMPLEMENTATION REQUIREMENTS

- Capital Costs
- O&M Costs
- Regulatory
- Training
- Staffing
- Administrative

■ High Medium Low

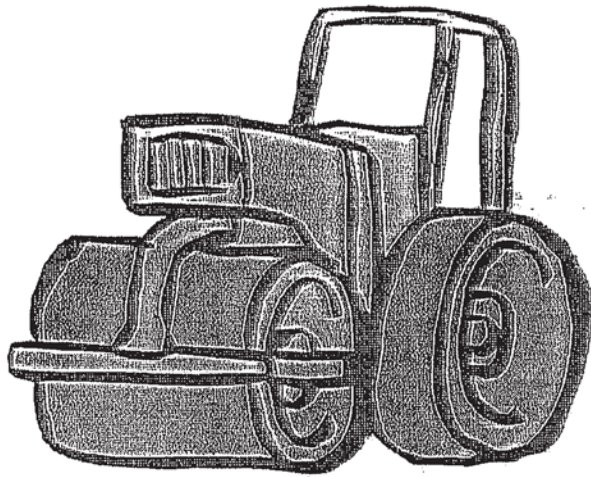

OBJECTIVES

- Housekeeping Practices
- Contain Waste
- Minimize Disturbed Areas
- Stabilize Disturbed Areas
- Protect Slopes/Channels
- Control Site Perimeter
- Control Internal Erosion



Developed by Salt Lake County

DESCRIPTION:

Use of rolling, tamping, or vibration to stabilize fill materials and control erosion by increasing the soil density. Increasing the density of soil improves soil strength, reduces long-term soil settlement, and provides resistance to erosion.

APPLICATIONS:

- ▶ Stabilize fill material placed around various structures.
- ▶ Improve soil in place as foundation support for roads, parking lots, and buildings.

INSTALLATION/APPLICATION CRITERIA:

- ▶ Make sure soil moisture content is at optimum levels.
- ▶ Use proper compaction equipment.
- ▶ Install sediment control and storm water management devices below compacted areas and runoff interceptor devices above these areas. Drainage from compacted areas must be carefully planned to protect adjacent uncompacted soils.
- ▶ The surface of compacted areas should be scarified and seeded or mulched and seeded to increase the effectiveness of compaction.

LIMITATIONS:

- ▶ Compaction tends to increase runoff.
- ▶ Over-compaction will hamper revegetation efforts.

MAINTENANCE:

No maintenance required.

TARGETED POLLUTANTS

- Sediment
- Nutrients
- Toxic Materials
- Oil & Grease
- Floatable Materials
- Other Waste

- High Impact
- Medium Impact
- Low or Unknown Impact

IMPLEMENTATION REQUIREMENTS

- Capital Costs
- O&M Costs
- Maintenance
- Training

- High
- Medium
- Low

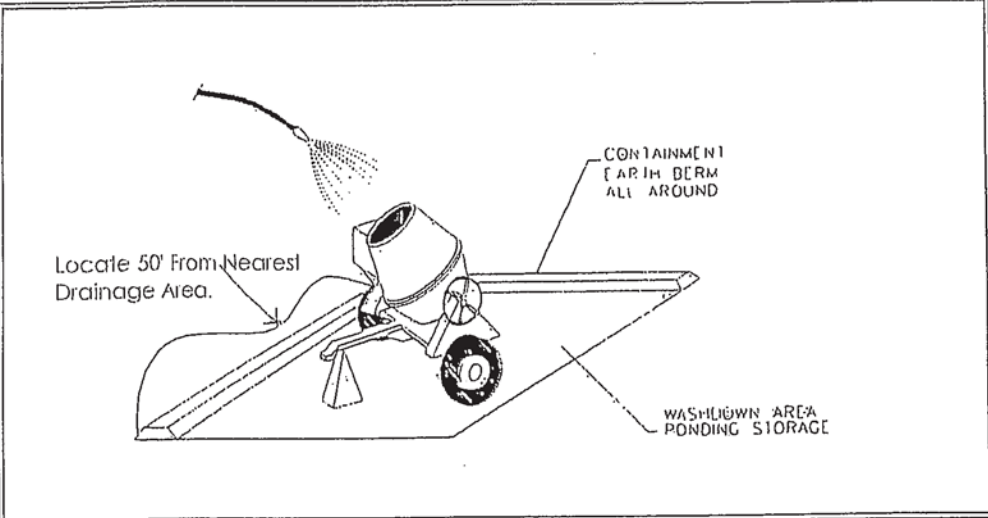

DESCRIPTION:

Prevent or reduce the discharge of pollutants to storm water from concrete waste by conducting washout off-site, performing on-site washout in a designated area, and training employees and subcontractors.

APPLICATIONS:

This technique is applicable to all types of sites.

INSTALLATION/APPLICATION CRITERIA:

- ▶ Store dry and wet materials under cover, away from drainage areas.
- ▶ Avoid mixing excess amounts of fresh concrete or cement on-site.
- ▶ Perform washout of concrete trucks off-site or in designated areas only.
- ▶ Do not wash out concrete trucks into storm drains, open ditches, streets, or streams.
- ▶ Do not allow excess concrete to be dumped on-site, except in designated areas.
- ▶ When washing concrete to remove fine particles and expose the aggregate, avoid creating runoff by draining the water within a bermed or level area. (See Earth Berm Barrier information sheet.)
- ▶ Train employees and subcontractors in proper concrete waste management.

LIMITATIONS:

- ▶ Off-site washout of concrete wastes may not always be possible.

MAINTENANCE:

- ▶ Inspect subcontractors to ensure that concrete wastes are being properly managed.
- ▶ If using a temporary pit, dispose hardened concrete on a regular basis.

OBJECTIVES

- Housekeeping Practices
- Contain Waste
- Minimize Disturbed Areas
- Stabilize Disturbed Areas
- Protect Slopes/Channels
- Control Site Perimeter
- Control Internal Erosion



Developed by Salt Lake County

TARGETED POLLUTANTS

- Sediment
- Nutrients
- Toxic Materials
- Oil & Grease
- Floatable Materials
- Other Waste

- High Impact
- Medium Impact
- Low or Unknown Impact

IMPLEMENTATION REQUIREMENTS

- Capital Costs
- O&M Costs
- Maintenance
- Training

High Medium Low

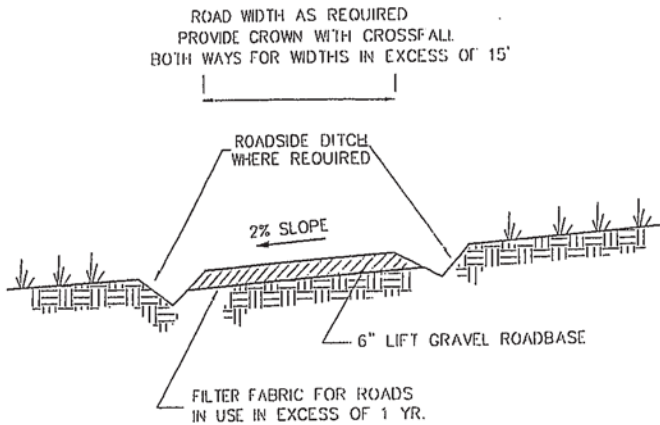

OBJECTIVES

- Housekeeping Practices
- Contain Waste
- Minimize Disturbed Areas
- Stabilize Disturbed Areas
- Protect Slopes/Channels
- Control Site Perimeter
- Control Internal Erosion



Developed by Salt Lake County

TARGETED POLLUTANTS

- Sediment
- Nutrients
- Toxic Materials
- Oil & Grease
- Floatable Materials
- Other Waste

- High Impact
- Medium Impact
- Low or Unknown Impact

IMPLEMENTATION REQUIREMENTS

- Capital Costs
- O&M Costs
- Maintenance
- Training

- High
- Medium
- Low

DESCRIPTION:

Temporary stabilization of on-site roadway by placement of gravel roadbase.

APPLICATION:

- ▶ On-site roadways used daily by construction traffic (may not apply to gravelly type soils)
- ▶ Parking or staging areas susceptible to erosion due to traffic use

INSTALLATION/APPLICATION CRITERIA:

- ▶ Grade temporary access road with 2% cross fall, for two-way width provide crown.
- ▶ Provide roadside ditch and outlet controls where required.
- ▶ Place 6 inches of 2-inch to 4-inch crushed rock on driving area

LIMITATIONS:

- ▶ May require removal of gravel roadbase at completion of activities if final cover is not impervious
- ▶ May require controls for surface storm water runoff

MAINTENANCE:

- ▶ Inspect after major rainfall events and at least monthly.
- ▶ Place additional gravel as needed and repair any damaged areas.
- ▶ Maintain any roadside drainage controls.

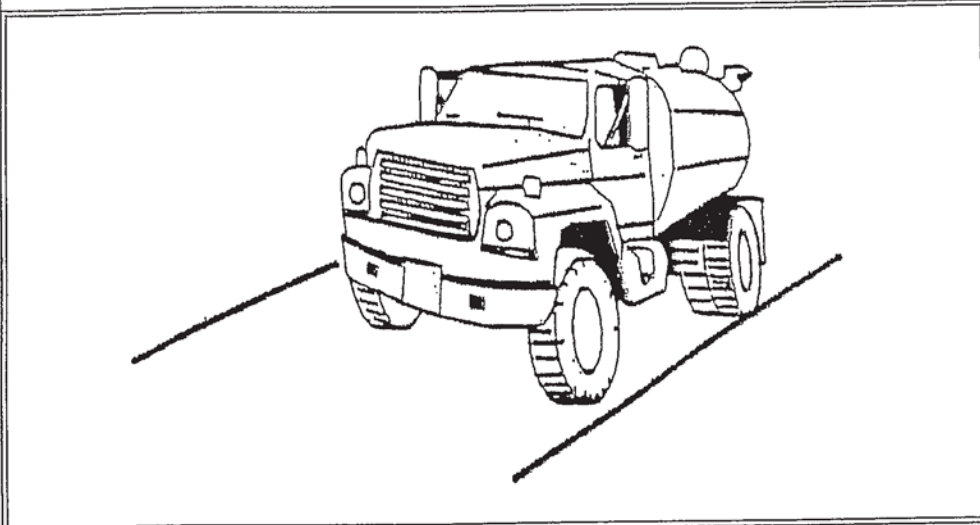

DESCRIPTION:

Dust control measures are used to stabilize soil from wind erosion, and reduce dust by construction activities.

APPLICATION:

Dust control is useful in any process area, loading and unloading area, material handling areas, and transfer areas where dust is generated. Street sweeping is limited to areas that are paved.

INSTALLATION/APPLICATION CRITERIA:

- ▶ Mechanical dust collection systems are designed according to the size of dust particles and the amount of air to be processed. Manufacturers' recommendations should be followed for installation (as well as the design of the equipment).
- ▶ Two kinds of street sweepers are common: brush and vacuum. Vacuum sweepers are more efficient and work best when the area is dry.
- ▶ Mechanical equipment should be operated according to the manufacturers' recommendations and should be inspected regularly.

LIMITATIONS:

- ▶ Is generally more expensive than manual systems.
- ▶ May be impossible to maintain by plant personnel (the more elaborate equipment).
- ▶ Is labor and equipment intensive and may not be effective for all pollutants (street sweepers).

MAINTENANCE:

If water sprayers are used, dust-contaminated waters should be collected and taken for treatment. Areas will probably need to be resprayed to keep dust from spreading.

OBJECTIVES

- Housekeeping Practices
- Contain Waste
- Minimize Disturbed Areas
- Stabilize Disturbed Areas
- Protect Slopes/Channels
- Control Site Perimeter
- Control Internal Erosion



Developed by Salt Lake County

TARGETED POLLUTANTS

- Sediment
- Nutrients
- Toxic Materials
- Oil & Grease
- Floatable Materials
- Other Waste

- High Impact
- Medium Impact
- Low or Unknown Impact

IMPLEMENTATION REQUIREMENTS

- Capital Costs
- O&M Costs
- Maintenance
- Training

High Medium Low

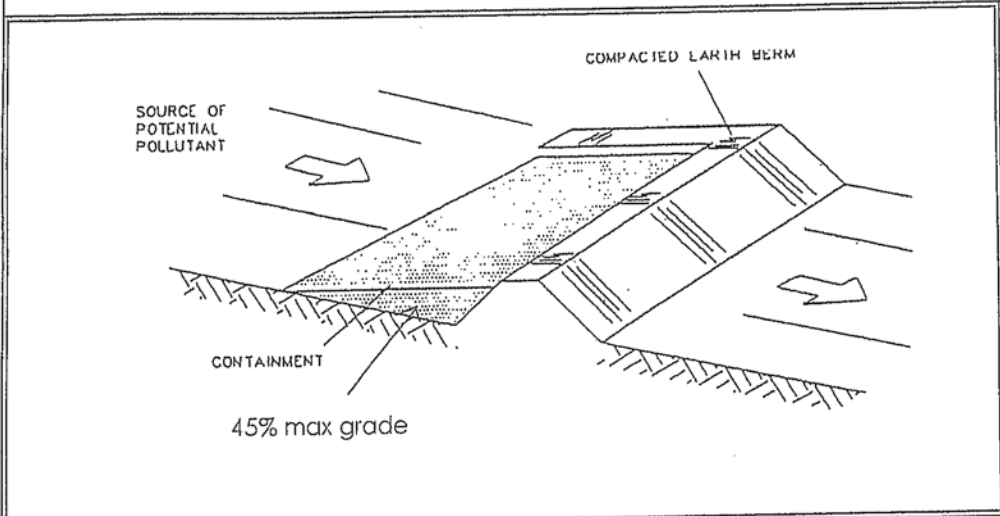

OBJECTIVES

- Housekeeping Practices
- Contain Waste
- Minimize Disturbed Areas
- Stabilize Disturbed Areas
- Protect Slopes/Channels
- Control Site Perimeter
- Control Internal Erosion



DESCRIPTION:

A temporary containment control constructed of compacted soil.

APPLICATION:

- ▶ Construct around waste and materials storage area.
- ▶ Construct around staging and maintenance areas.
- ▶ Construct around vehicle parking and servicing areas.

INSTALLATION/APPLICATION CRITERIA:

- ▶ Construct an earthen berm down hill of the area to be controlled. The berm should surround fueling facilities and maintenance areas on three sides to provide containment.
- ▶ Berm needs to be a minimum of 1 foot tall by 1 foot wide and be compacted by earth moving equipment.

LIMITATIONS:

- ▶ Not effective on steep slopes.
- ▶ Limits access to controlled area.
- ▶ Personnel need to quickly respond to spills with remedial actions.

MAINTENANCE:

- ▶ Observe daily for any non-stormwater discharge.
- ▶ Look for runoff bypassing ends of berms or undercutting berms.
- ▶ Repair or replace damaged areas of the berm and remove accumulated sediment.
- ▶ Recompact soil around berm as necessary to prevent piping.

TARGETED POLLUTANTS

- Sediment
- Nutrients
- Toxic Materials
- Oil & Grease
- Floatable Materials
- Other Construction Waste

- High Impact
- Medium Impact
- Low or Unknown Impact

IMPLEMENTATION REQUIREMENTS

- Capital Costs
- O&M Costs
- Maintenance
- Training

- High Medium Low

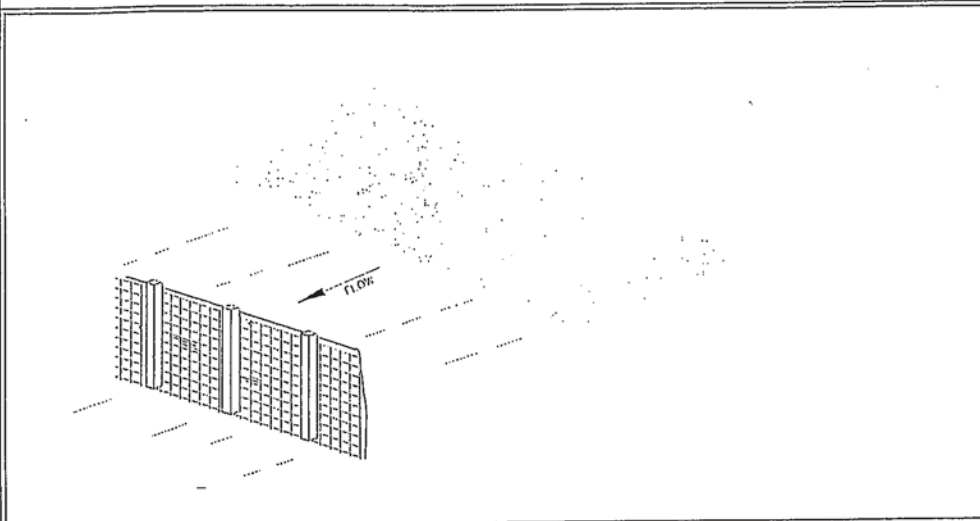

DESCRIPTION:

A stabilized pad of crushed stone for general washing of equipment and construction vehicles.

APPLICATION:

At any site where regular washing of vehicles and equipment will occur. May also be used as a filling point for water trucks limiting erosion caused by overflow or spillage of water.

INSTALLATION/APPLICATION CRITERIA:

- ▶ Clear and grub area and grade to provide maximum slope of 1%
- ▶ Compact subgrade and place filter fabric if desired (recommended for wash areas to remain in use for more than 3 months).
- ▶ Place coarse aggregate, 1 to 2-1/2 inches in size, to a minimum depth of 8-inches.
- ▶ Install silt fence downgradient (see silt fence BMP information sheet).

LIMITATIONS:

Cannot be utilized for washing equipment or vehicles that may cause contamination of runoff such as fertilizer equipment or concrete equipment. Solely used to control sediment in wash water.

MAINTENANCE:

- ▶ Inspect daily for loss of gravel or sediment buildup.
- ▶ Inspect adjacent area for sediment deposit and install additional controls as necessary.
- ▶ Repair area and replace gravel as required to maintain control in good working condition.
- ▶ Expand stabilized area as required to accommodate activities.
- ▶ Maintain silt fence as outlined in specific silt fence BMP information sheet.

OBJECTIVES

- Housekeeping Practices
- Contain Waste
- Minimize Disturbed Areas
- Stabilize Disturbed Areas
- Protect Slopes/Channels
- Control Site Perimeter
- Control Internal Erosion



Developed by Salt Lake County

TARGETED POLLUTANTS

- Sediment
- Nutrients
- Toxic Materials
- Oil & Grease
- Floatable Materials
- Other Waste

- High Impact
- Medium Impact
- Low or Unknown Impact

IMPLEMENTATION REQUIREMENTS

- Capital Costs
- O&M Costs
- Maintenance
- Training

- High Medium Low

BMP: Geotextiles and Mats

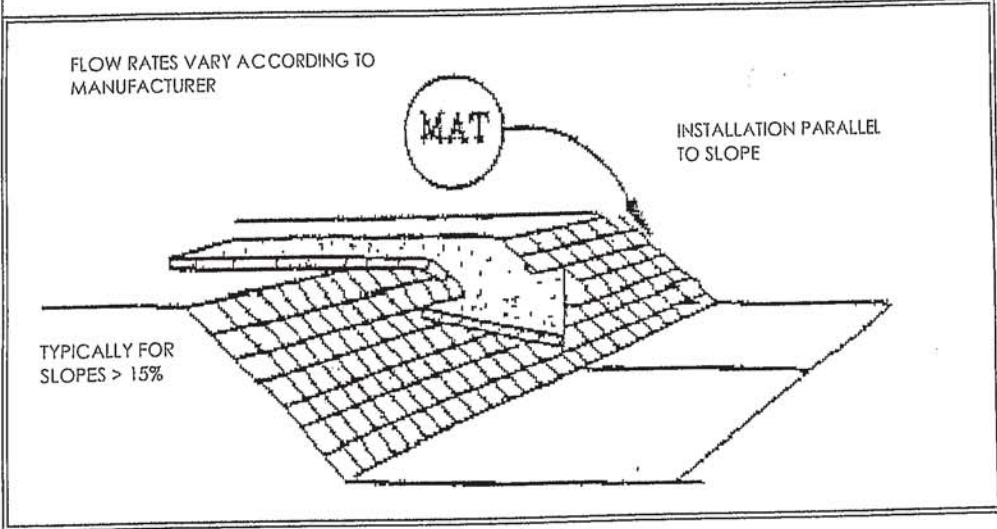

OBJECTIVES

- Housekeeping Practices
- Contain Waste
- Minimize Disturbed Areas
- Stabilize Disturbed Areas
- Protect Slopes/Channels
- Control Site Perimeter
- Control Internal Erosion



Developed by Salt Lake County

DESCRIPTION:

Mattings made of natural or synthetic material which are used to temporarily or permanently stabilize soil.

APPLICATION:

- ▶ Typically suited for post-construction site stabilization, but may be used for temporary stabilization of highly erosive soils.
- ▶ Channels and streams.
- ▶ Steep slopes.

INSTALLATION/APPLICATION CRITERIA:

- ▶ Mattings may be applied to disturbed soils and where existing vegetation has been removed.
- ▶ The following organic matting materials provide temporary protection until permanent vegetation is established, or when seasonal circumstances dictate the need for temporary stabilization until weather or construction delays are resolved: Jute mattings and straw mattings.
- ▶ The following synthetic mattings may be used for either temporary or post-construction stabilization, both with and without vegetation: excelsior matting, glass fiber matting, mulch matting.
- ▶ Staples are needed to anchor the matting.

LIMITATIONS:

- ▶ Mattings are more costly than other BMP practices, limiting their use to areas where other BMPs are ineffective (e.g., channels, steep slopes).
- ▶ May delay seed germination, due to reduction in soil temperature.
- ▶ Installation requires experienced contractor to ensure soil stabilization and erosion protection.

MAINTENANCE:

- ▶ Inspect monthly and after significant rainfall.
- ▶ Re-anchor loosened matting and replace missing matting and staples as required.

TARGETED POLLUTANTS

- Sediment
- Nutrients
- Toxic Materials
- Oil & Grease
- Floatable Materials
- Other Waste

- High Impact
- Medium Impact
- Low or Unknown Impact

IMPLEMENTATION REQUIREMENTS

- Capital Costs
- O&M Costs
- Maintenance
- Training

- High
- Medium
- Low

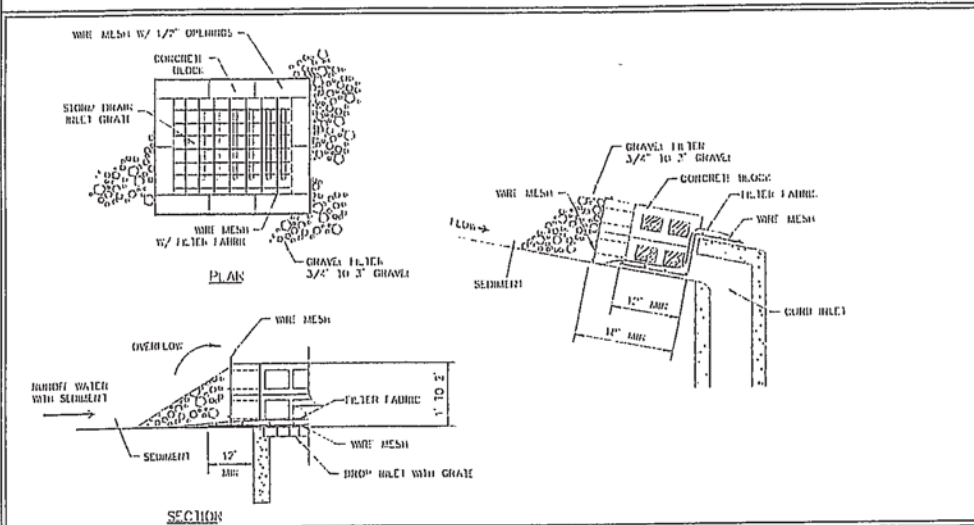

OBJECTIVES

- Housekeeping Practices
- Contain Waste
- Minimize Disturbed Areas
- Stabilize Disturbed Areas
- Protect Slopes/Channels
- Control Site Perimeter
- Control Internal Erosion



Developed by Salt Lake County

DESCRIPTION:

Concrete block and gravel filter placed over inlet to storm drain system.

APPLICATION:

Construct at inlets in paved or unpaved areas where upgradient area is to be disturbed by construction activities.

INSTALLATION/APPLICATION CRITERIA:

- Place wire mesh (with 1/2 inch openings) over the inlet grate extending one foot past the grate in all directions.
- Place concrete blocks around the inlet with openings facing outward. Stack blocks to minimum height of 12-inches and maximum height of 24-inches.
- Place wire mesh around outside of blocks.
- Place gravel (3/4" to 3") around blocks.

LIMITATIONS:

- Recommended for maximum drainage area of one acre.
- Excess flows may bypass the inlet requiring down gradient controls.
- Ponding will occur at inlet.

MAINTENANCE:

- Inspect inlet protection after every large storm event and at a minimum of once monthly.
- Remove sediment accumulated when it reaches 4-inches in depth.
- Replace filter fabric and clean or replace gravel if clogging is apparent.

TARGETED POLLUTANTS

- Sediment
- Nutrients
- Toxic Materials
- Oil & Grease
- Floatable Materials
- Other Waste

- High Impact
- Medium Impact
- Low or Unknown Impact

IMPLEMENTATION REQUIREMENTS

- Capital Costs
- O&M Costs
- Maintenance
- Training

- High
- Medium
- Low

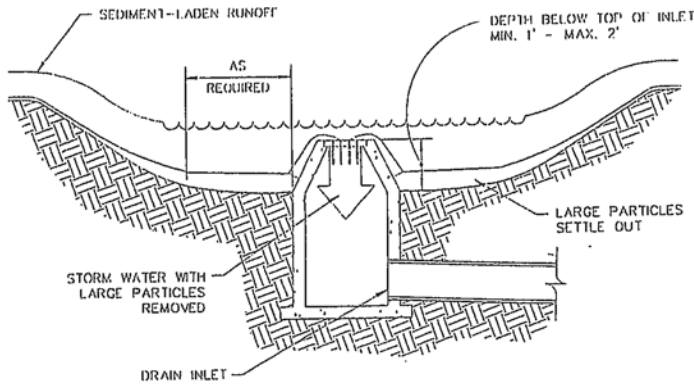

OBJECTIVES

- Housekeeping Practices
- Contain Waste
- Minimize Disturbed Areas
- Stabilize Disturbed Areas
- Protect Slopes/Channels
- Control Site Perimeter
- Control Internal Erosion



Developed by Salt Lake County

DESCRIPTION:

An area excavated around a storm drain inlet to impound water below the inlet.

APPLICATION:

Construct at storm drainage inlets located downgradient of areas to be disturbed by construction (for inlets in paved areas see other information sheets for inlet protection).

INSTALLATION/APPLICATION CRITERIA:

- ▶ Provide upgradient sediment controls, such as silt fence during construction of inlet.
- ▶ When construction of inlet is complete, excavate adjacent area 1 to 2 feet lower than the grate elevation. Size of excavated area should be based on soil type and contributing acreage.

LIMITATIONS:

- ▶ Recommended maximum contributing drainage area of one acre.
- ▶ Limited to inlets located in open unpaved areas.
- ▶ Requires flat area adjacent to inlet.

MAINTENANCE:

- ▶ Inspect inlet protection following storm event and at a minimum of once monthly.
- ▶ Remove accumulated sediment when it reaches one half of the excavated sump below the grate.
- ▶ Repair side slopes as required.

TARGETED POLLUTANTS

- Sediment
- Nutrients
- Toxic Materials
- Oil & Grease
- Floatable Materials
- Other Waste

- High Impact
- Medium Impact
- Low or Unknown Impact

IMPLEMENTATION REQUIREMENTS

- Capital Costs
- O&M Costs
- Maintenance
- Training

- High
- Medium
- Low

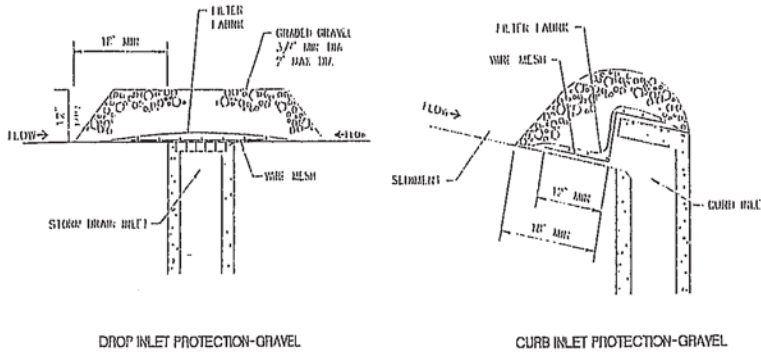

OBJECTIVES

- Housekeeping Practices
- Contain Waste
- Minimize Disturbed Areas
- Stabilize Disturbed Areas
- Protect Slopes/Channels
- Control Site Perimeter
- Control Internal Erosion



Developed by Salt Lake County

DESCRIPTION:

Placement of gravel filter over inlet to storm drain to filter storm water runoff.

APPLICATION:

Construct at inlets in paved or unpaved areas where upgradient area is to be disturbed by construction activities.

INSTALLATION/APPLICATION CRITERIA:

- ▶ Place wire mesh (with 1/2 inch openings) over the inlet grate extending one foot past the grate in all directions.
- ▶ Place filter fabric over the mesh. Filter fabric should be selected based on soil type.
- ▶ Place graded gravel, to a minimum depth of 12-inches, over the filter fabric and extending 18-inches past the grate in all directions.

LIMITATIONS:

- ▶ Recommended for maximum drainage area of one acre.
- ▶ Excess flows may bypass the inlet requiring down gradient controls.
- ▶ Ponding will occur at inlet.

MAINTENANCE:

- ▶ Inspect inlet protection after every large storm event and at a minimum of once monthly.
- ▶ Remove sediment accumulated when it reaches 4-inches in depth.
- ▶ Replace filter fabric and clean or replace gravel if clogging is apparent.

TARGETED POLLUTANTS

- Sediment
- Nutrients
- Toxic Materials
- Oil & Grease
- Floatable Materials
- Other Waste

- High Impact
- Medium Impact
- Low or Unknown Impact

IMPLEMENTATION REQUIREMENTS

- Capital Costs
- O&M Costs
- Maintenance
- Training

- High Medium Low

INLET PROTECTION

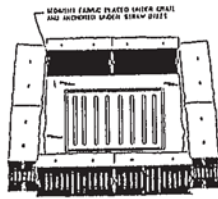

STRAW BALE BARRIER

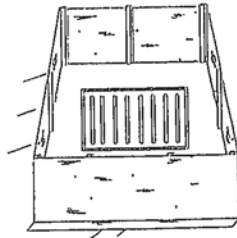

SILT FENCE

SEE INDIVIDUAL BMP INFORMATION SHEETS FOR INSTRUCTIONS FOR CONSTRUCTION OF STRAW BALE BARRIER AND SILT FENCE..

DESCRIPTION:

Sediment barrier erected around storm drain inlet.

APPLICATION:

Construct at storm drainage inlets located downgradient of areas to be disturbed by construction (for inlets in paved areas see other information sheets for inlet protection).

INSTALLATION/APPLICATION CRITERIA:

- ▶ Provide upgradient sediment controls, such as silt fence during construction of inlet.
- ▶ When construction of inlet is complete, erect straw bale barrier or silt fence surrounding perimeter of inlet. Follow instructions and guidelines on individual BMP information sheets for straw bale barrier and silt fence construction.

LIMITATIONS:

- ▶ Recommended maximum contributing drainage area of one acre.
- ▶ Limited to inlets located in open unpaved areas.
- ▶ Requires shallow slopes adjacent to inlet.

MAINTENANCE:

- ▶ Inspect inlet protection following storm event and at a minimum of once monthly.
- ▶ Remove accumulated sediment when it reaches 4-inches in depth.
- ▶ Repair or realign barrier/fence as needed.
- ▶ Look for bypassing or undercutting and recompact soil around barrier/fence as required.

OBJECTIVES

- Housekeeping Practices
- Contain Waste
- Minimize Disturbed Areas
- Stabilize Disturbed Areas
- Protect Slopes/Channels
- Control Site Perimeter
- Control Internal Erosion



Developed by Salt Lake County

TARGETED POLLUTANTS

- Sediment
- Nutrients
- Toxic Materials
- Oil & Grease
- Floatable Materials
- Other Waste

- High Impact
- Medium Impact
- Low or Unknown Impact

IMPLEMENTATION REQUIREMENTS

- Capital Costs
- O&M Costs
- Maintenance
- Training

- High
- Medium
- Low

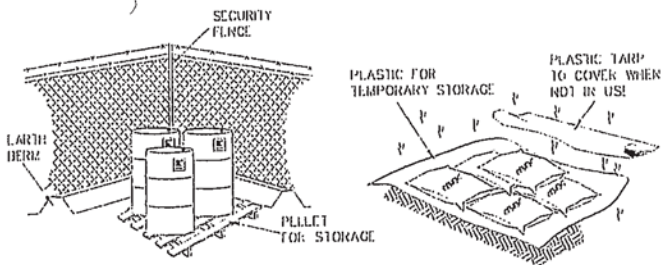

- ▶ CONTROLLED STORAGE LOCATION
- ▶ BERMED PERIMETER IMPOUNDMENT
- ▶ STORAGE OFF GROUND
- ▶ COVER WHEN NOT IN USE

DESCRIPTION:

Controlled storage of on-site materials.

APPLICATION:

- ▶ Storage of hazardous, toxic, and all chemical substances.
- ▶ Any construction site with outside storage of materials.

INSTALLATION/APPLICATION CRITERIA:

- ▶ Designate a secured area with limited access as the storage location. Ensure no waterways or drainage paths are nearby.
- ▶ Construct compacted earthen berm (See Earth Berm Barrier Information Sheet), or similar perimeter containment around storage location for impoundment in the case of spills.
- ▶ Ensure all on-site personnel utilize designated storage area. Do not store excessive amounts of material that will not be utilized on site.
- ▶ For active use of materials away from the storage area ensure materials are not set directly on the ground and are covered when not in use. Protect storm drainage during use.

LIMITATIONS:

- ▶ Does not prevent contamination due to mishandling of products.
- ▶ Spill Prevention and Response Plan still required.
- ▶ Only effective if materials are actively stored in controlled location.

MAINTENANCE:

- ▶ Inspect daily and repair any damage to perimeter impoundment or security fencing.
- ▶ Check materials are being correctly stored (i.e. standing upright, in labeled containers, tightly capped) and that no materials are being stored away from the designated location.

OBJECTIVES

- Housekeeping Practices
- Contain Waste
- Minimize Disturbed Areas
- Stabilize Disturbed Areas
- Protect Slopes/Channels
- Control Site Perimeter
- Control Internal Erosion



Developed by Salt Lake County

TARGETED POLLUTANTS

- Sediment
- Nutrients
- Toxic Materials
- Oil & Grease
- Floatable Materials
- Other Waste

- High Impact
- Medium Impact
- Low or Unknown Impact

IMPLEMENTATION REQUIREMENTS

- Capital Costs
- O&M Costs
- Maintenance
- Training

- High
- Medium
- Low

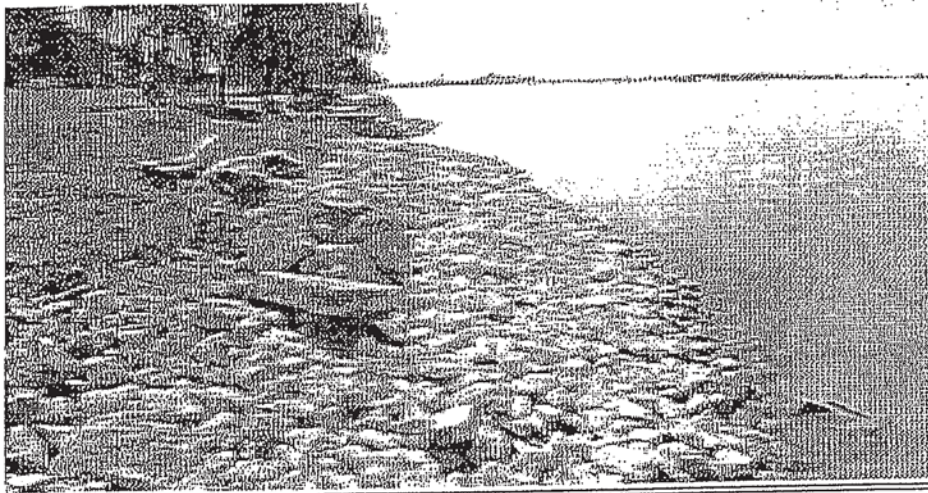

CONSIDERATIONS

- Soils
- Area Required
- Slope
- Water Availability
- Aesthetics
- Hydraulic Head
- Environmental Side Effects



Developed by Salt Lake County

DESCRIPTION:

Riprap is a permanent, erosion-resistant protective layer made of loose stones. It is intended to protect soil from erosion in areas of concentrated runoff. Riprap may also be used to stabilize slopes that are unstable because of seepage problems.

APPLICATION:

- ▶ Riprap is normally used at locations where erosive forces from water flow exceed the ability of the soil or vegetative cover to resist those forces.
- ▶ Riprap can be used for pipe outlet protection, channel lining, scour protection, etc.
- ▶ Riprap is commonly used for wave protection on lakes.

INSTALLATION/APPLICATION CRITERIA:

- ▶ For slopes steeper than 2:1, consider using materials other than riprap for erosion protection.
- ▶ If riprap is being planned for the bottom of a permanently flowing channel, the bottom can be modified to enhance fish habitat. This can be done by constructing riffles and pools which simulate natural conditions.
- ▶ When working within flowing streams, measures should be taken to prevent excessive turbidity and erosion during construction. Bypassing base flows or temporarily blocking base flows are two possible methods. Work should be done during a period of low flow.

In designing riprap consider the following:

- ▶ Use durable rock, such as granite, and a variety of rock sizes.
- ▶ The thickness of riprap layers should be at least 1.25 times the max. stone diameter.
- ▶ Filter material is usually required between riprap and the underlying soil surface.

LIMITATIONS:

- ▶ Riprap may be unstable on very steep slopes.
- ▶ The placement of a riprap in streams requires a state stream alteration permit.

MAINTENANCE:

- ▶ Riprap should be inspected annually and after major storms.
- ▶ If riprap has been damaged, repairs should be made promptly to prevent a progressive failure.
- ▶ If repairs are needed repeatedly at one location, the site should be evaluated to see if original design conditions have changed.

TARGETED POLLUTANTS

- Sediment
- Nutrients
- Heavy Metals
- Toxic Materials
- Oxygen Demanding Substances
- Oil & Grease
- Floatable Materials
- Bacteria & Viruses

IMPLEMENTATION REQUIREMENTS

- High Impact
- Medium Impact
- Capital Costs
- Low or Unknown Impact
- O&M Costs
- Maintenance
- Training

■ High Medium Low

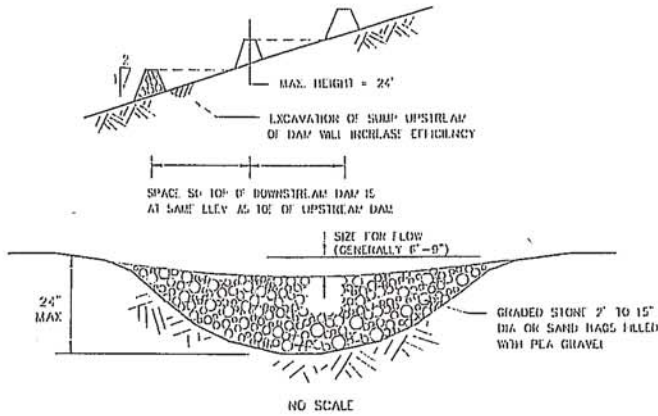

DESCRIPTION:

A small, temporary dam constructed across a drainage ditch to reduce velocity of concentrated storm water flows, thereby reducing the erosion of the ditch.

APPLICATION:

- ▶ Temporary drainage paths
- ▶ Permanent drainage ways not yet stabilized
- ▶ Existing drainage paths receiving increased flows due to construction

INSTALLATION/APPLICATION CRITERIA:

- ▶ Prepare location of dam by removing any debris and rough grading any irregularities in channel bottom
- ▶ Place rocks by hand or with appropriate machinery, do not dump
- ▶ Construct dam with center lower to pass design flow
- ▶ Construct 50% side slopes on dam

LIMITATIONS:

- ▶ Maximum recommended drainage area is 10 acres
- ▶ Maximum recommended height is 24"
- ▶ Do not use in running stream

MAINTENANCE:

- ▶ Inspect dams daily during prolonged rainfall, after each major rain event and at a minimum of once monthly.
- ▶ Remove any large debris and repair any damage to dam, channel or sideslopes
- ▶ Remove accumulated sediment when it reaches one half the height of the dam

OBJECTIVES

- Housekeeping Practices
- Contain Waste
- Minimize Disturbed Areas
- Stabilize Disturbed Areas
- Protect Slopes/Channels
- Control Site Perimeter
- Control Internal Erosion



Developed by Salt Lake County

TARGETED POLLUTANTS

- Sediment
- Nutrients
- Toxic Materials
- Oil & Grease
- Floatable Materials
- Other Waste

- High Impact
- Medium Impact
- Low or Unknown Impact

IMPLEMENTATION REQUIREMENTS

- Capital Costs
- O&M Costs
- Maintenance
- Training

- High
- Medium
- Low

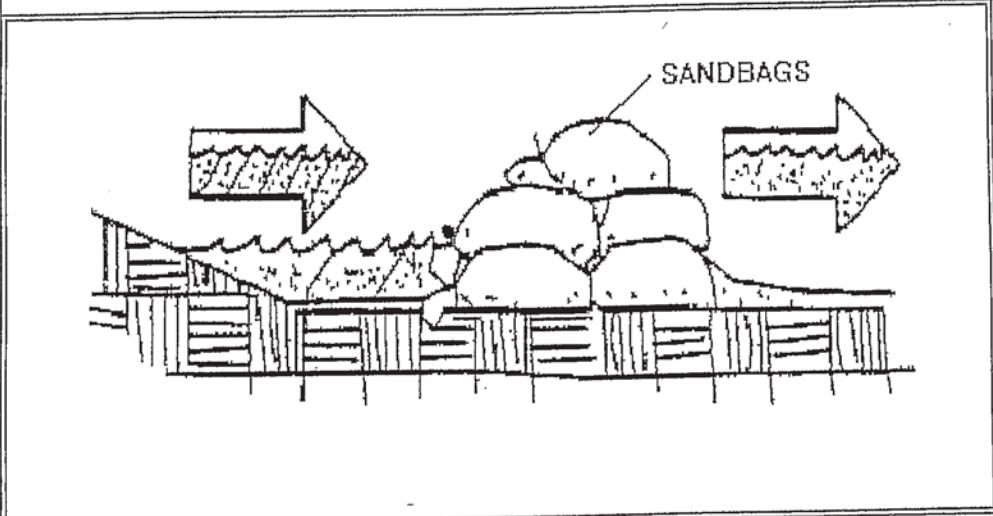

DESCRIPTION:

Stacking sand bags along a level contour creates a barrier which detains sediment-laden water, ponding water upstream of the barrier and promoting sedimentation.

APPLICATION:

- ▶ Along the perimeter of the site.
- ▶ May be used in drainage areas up to 5 acres.
- ▶ Along streams and channels
- ▶ Across swales with small catchments.
- ▶ Around temporary spoil areas.
- ▶ Below the toe of a cleared slope.

INSTALLATION/APPLICATION CRITERIA:

- ▶ Install along a level contour.
- ▶ Base of sand bag barrier should be at least 48 inches wide.
- ▶ Height of sand bag barrier should be at least 18 inches high.
- ▶ 4 inch PVC pipe may be installed between the top layer of sand bags to drain large flood flows.
- ▶ Provide area behind barrier for runoff to pond and sediment to settle.
- ▶ Place below the toe of a slope.

LIMITATIONS:

- ▶ Sand bags are more expensive than other barriers, but also more durable.
- ▶ Burlap should not be used.

MAINTENANCE:

- ▶ Inspect after each rain.
- ▶ Reshape or replace damaged sand bags immediately.
- ▶ Replace sediment when it reaches six inches in depth.

OBJECTIVES

- Housekeeping Practices
- Contain Waste
- Minimize Disturbed Areas
- Stabilize Disturbed Areas
- Protect Slopes/Channels
- Control Site Perimeter
- Control Internal Erosion



Developed by Salt Lake County

TARGETED POLLUTANTS

- Sediment
- Nutrients
- Toxic Materials
- Oil & Grease
- Floatable Materials
- Other Waste

- High Impact
- Medium Impact
- Low or Unknown Impact

IMPLEMENTATION REQUIREMENTS

- Capital Costs
- O&M Costs
- Maintenance
- Training

- High Medium Low

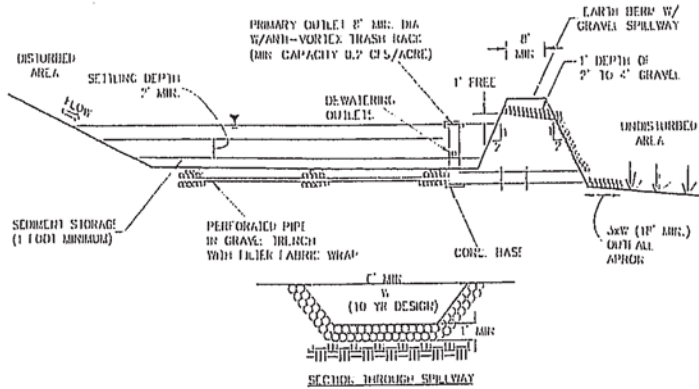

OBJECTIVES

- Housekeeping Practices
- Contain Waste
- Minimize Disturbed Areas
- Stabilize Disturbed Areas
- Protect Slopes/Channels
- Control Site Perimeter
- Control Internal Erosion



Developed by Salt Lake County

DESCRIPTION:

A pond created by excavation or construction of an embankment, and designed to retain or detain runoff sufficiently to allow excessive sediment to settle.

APPLICATION:

- ▶ At the outlet of all disturbed watersheds 10 acres or larger.
- ▶ At the outlet of smaller disturbed watersheds, as necessary.
- ▶ Where post construction detention basins will be located.

INSTALLATION/APPLICATION CRITERIA:

- ▶ Design basin for site specific location, maintain effective flow length 2 times width.
- ▶ Excavate basin or construct compacted berm containment, ensure no downgradient hazard if failure should occur. (Provide minimum of 67 cy. per acre of drainage area).
- ▶ Construct dewatering and outfall structure and emergency spillway with apron.

LIMITATIONS:

- ▶ Should be sized based on anticipated runoff, sediment loading and drainage area size.
- ▶ May require silt fence at outlet for entrapment of very fine silts and clays.
- ▶ May require safety fencing to prevent public access.
- ▶ Height restrictions for embankment regulated by Utah Division of Dam Safety.

MAINTENANCE:

- ▶ Inspect after each rainfall event and at a minimum of monthly.
- ▶ Repair any damage to berm, spillway or sidewalls.
- ▶ Remove accumulated sediment as it reaches 2/3 height of available storage.
- ▶ Check outlet for sedimentation/erosion of downgradient area and remediate as necessary. Install silt fence if sedimentation apparent.

TARGETED POLLUTANTS

- Sediment
- Nutrients
- Toxic Materials
- Oil & Grease
- Floatable Materials
- Other Waste

- High Impact
- Medium Impact
- Low or Unknown Impact

IMPLEMENTATION REQUIREMENTS

- Capital Costs
- O&M Costs
- Maintenance
- Training

- High
- Medium
- Low

BMP: Sediment Trap

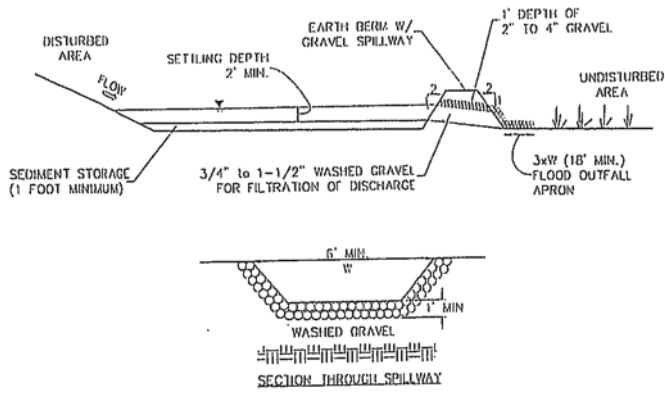

OBJECTIVES

- Housekeeping Practices
- Contain Waste
- Minimize Disturbed Areas
- Stabilize Disturbed Areas
- Protect Slopes/Channels
- Control Site Perimeter
- Control Internal Erosion



Developed by Salt Lake County

DESCRIPTION:

A sediment trap is a small excavated or bermed area where runoff from small drainage areas is detained and sediment can settle.

APPLICATION:

- Temporary control for runoff from disturbed areas of less than 3 acres.
- Temporary control for discharge from diversion dike, surface benching, or other temporary drainage measures.

INSTALLATION/APPLICATION CRITERIA:

- Design basin for site specific location.
- Excavate basin or construct compacted berm containment.
- Construct outfall spillway with apron.
- Provide downstream silt fence if necessary.

LIMITATIONS:

- Should be sized based on anticipated runoff, sediment loading and drainage area size.
- May require silt fence at outlet for entrapment of very fine silts and clays.

MAINTENANCE:

- Inspect after each rainfall event and at a minimum of monthly.
- Repair any damage to berm, spillway or sidewalls.
- Remove accumulated sediment as it reaches 2/3 height of available storage.
- Check outlet for sedimentation/erosion of downgradient area and remediate as necessary. Install silt fence if sedimentation apparent.

TARGETED POLLUTANTS

- Sediment
- Nutrients
- Toxic Materials
- Oil & Grease
- Floatable Materials
- Other Waste

- High Impact
- Medium Impact
- Low or Unknown Impact

IMPLEMENTATION REQUIREMENTS

- Capital Costs
- O&M Costs
- Maintenance
- Training

- High
- Medium
- Low

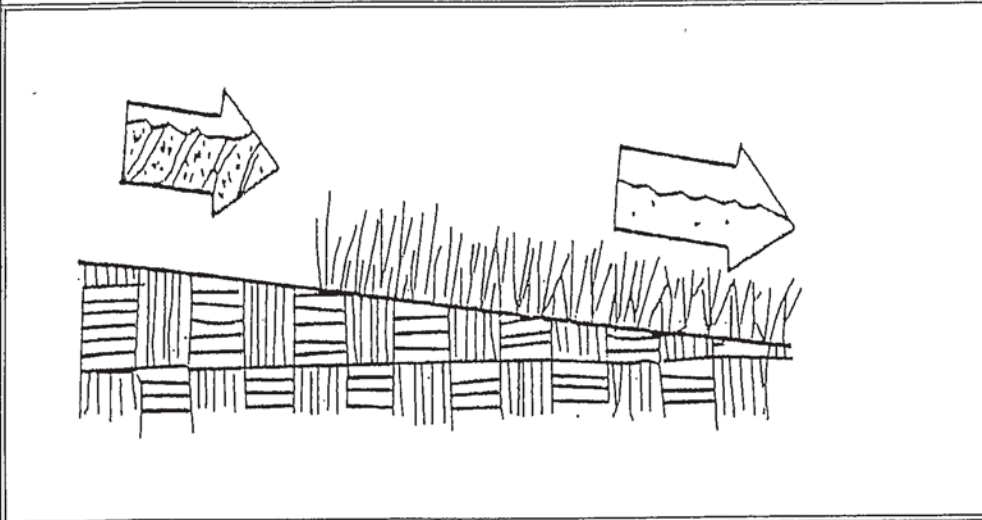

DESCRIPTION:

Seeding of grass and plantings of trees, shrubs, vines and ground covers provide long-term stabilization of soil. In some areas, with suitable climates, grasses can be planted for temporary stabilization.

APPLICATION:

- Appropriate for site stabilization both during construction and post-construction.
- Any graded/cleared areas where construction activities have ceased.
- Open space cut and fill areas.
- Steep slopes, spoil piles, vegetated swales, landscape corridors, stream banks.

INSTALLATION/APPLICATION CRITERIA:

Type of vegetation, site and seedbed preparation, planting time, fertilization and water requirements should be considered for each application.

Grasses:

- Ground preparation: fertilize and mechanically stabilize the soil.
- Tolerant of short-term temperature extremes and waterlogged soil composition.
- Appropriate soil conditions: shallow soil base, good drainage, slope 2:1 or flatter.
- Mowing, irrigating, and fertilizing are vital for promoting vigorous grass growth.

Trees and Shrubs:

- Selection criteria: vigor, species, size, shape & wildlife food source.
- Soil conditions: select species appropriate for soil, drainage & acidity.
- Other factors: wind/exposure, temperature extremes, and irrigation needs.

Vines and Ground Covers:

- Ground preparation: lime and fertilizer preparation.
- Use proper seeding rates.
- Appropriate soil conditions: drainage, acidity and slopes.
- Generally avoid species requiring irrigation.

LIMITATIONS:

- Permanent and temporary vegetation may not be appropriate in dry periods without irrigation.
- Fertilizer requirements may have potential to create stormwater pollution.

MAINTENANCE:

- Shrubs and trees must be adequately watered and fertilized and if needed pruned.
- Grasses may need to be watered and mowed.

OBJECTIVES

- Housekeeping Practices
- Contain Waste
- Minimize Disturbed Areas
- Stabilize Disturbed Areas
- Protect Slopes/Channels
- Control Site Perimeter
- Control Internal Erosion



Developed by Salt Lake County

TARGETED POLLUTANTS

- Sediment
- Nutrients
- Toxic Materials
- Oil & Grease
- Floatable Materials
- Other Waste

IMPLEMENTATION REQUIREMENTS

- Medium Impact
- Capital/Urban Impact
- O&M Costs
- Maintenance
- Training

High Medium Low

BMP: Silt Fence

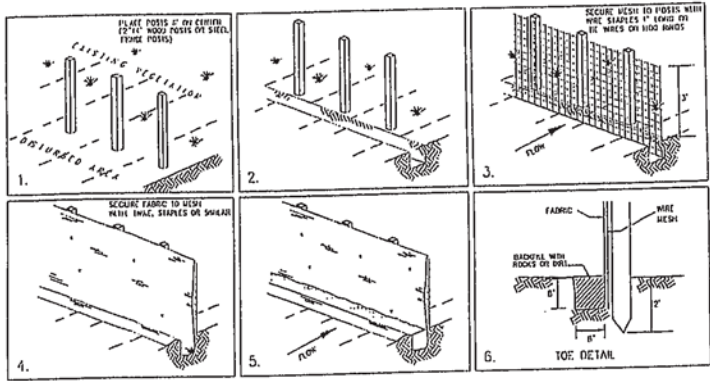

DESCRIPTION:

A temporary sediment barrier consisting of entrenched filter fabric stretched across and secured to supporting posts.

APPLICATION:

- ▶ Perimeter control: place barrier at downgradient limits of disturbance
- ▶ Sediment barrier: place barrier at toe of slope or soil stockpile
- ▶ Protection of existing waterways: place barrier at top of stream bank
- ▶ Inlet protection: place fence surrounding catchbasins

INSTALLATION/APPLICATION CRITERIA:

- ▶ Place posts 6 feet apart on center along contour (or use preassembled unit) and drive 2 feet minimum into ground. Excavate an anchor trench immediately upgradient of posts.
- ▶ Secure wire mesh (14 gage min. With 6 inch openings) to upslope side of posts. Attach with heavy duty 1 inch long wire staples, tie wires or hog rings.
- ▶ Cut fabric to required width, unroll along length of barrier and drape over barrier. Secure fabric to mesh with twine, staples, or similar, with trailing edge extending into anchor trench.
- ▶ Backfill trench over filter fabric to anchor.

LIMITATIONS:

- ▶ Recommended maximum drainage area of 0.5 acre per 100 feet of fence
- ▶ Recommended maximum upgradient slope length of 150 feet
- ▶ Recommended maximum uphill grade of 2:1 (50%)
- ▶ Recommended maximum flow rate of 0.5 cfs
- ▶ Ponding should not be allowed behind fence

MAINTENANCE:

- ▶ Inspect immediately after any rainfall and at least daily during prolonged rainfall.
- ▶ Look for runoff bypassing ends of barriers or undercutting barriers.
- ▶ Repair or replace damaged areas of the barrier and remove accumulated sediment.
- ▶ Reanchor fence as necessary to prevent shortcutting.
- ▶ Remove accumulated sediment when it reaches 1/2 the height of the fence.

OBJECTIVES

- Housekeeping Practices
- Contain Waste
- Minimize Disturbed Areas
- Stabilize Disturbed Areas
- Protect Slopes/Channels
- Control Site Perimeter
- Control Internal Erosion



TARGETED POLLUTANTS

- Sediment
- Nutrients
- Toxic Materials
- Oil & Grease
- Floatable Materials
- Other Waste

<p><input checked="" type="checkbox"/> High Impact</p> <p><input checked="" type="checkbox"/> Medium Impact</p> <p><input type="checkbox"/> Low or Unknown Impact</p> <p><input checked="" type="checkbox"/> Capital Costs</p> <p><input checked="" type="checkbox"/> O&M Costs</p> <p><input checked="" type="checkbox"/> Maintenance</p> <p><input type="checkbox"/> Training</p>	<p>IMPLEMENTATION REQUIREMENTS</p>
<p><input checked="" type="checkbox"/> High <input checked="" type="checkbox"/> Medium <input type="checkbox"/> Low</p>	

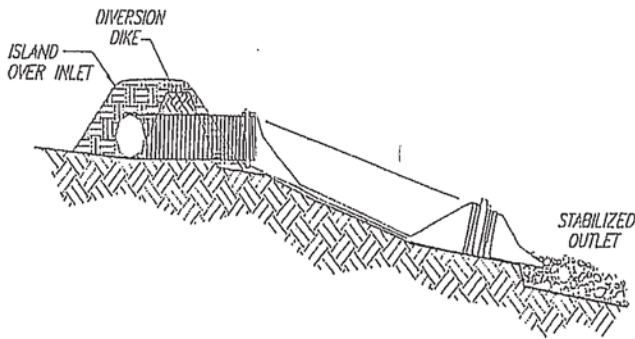

DESCRIPTION:

A temporary pipe or lined channel that drains the top of a slope to a stable discharge point at the bottom of a slope without causing erosion.

APPLICATIONS:

- ▶ Where concentrated flow of surface runoff must be conveyed down a slope in order to prevent erosion.
- ▶ Drainage for top slope diversion dikes or swales.
- ▶ Emergency spillway for a sediment basin.
- ▶ Drainage for top of cut/fill slopes where water can accumulate.

INSTALLATION/APPLICATION CRITERIA:

- ▶ Secure inlet and surround with dikes to prevent gully erosion, and anchor pipe to slope.
- ▶ Size to convey at least the peak of a 10-year, storm event.
- ▶ Stabilize outlet. (See Outlet Protection BMP).

LIMITATIONS:

- ▶ Maximum drainage area per slope drain is 5 acres.
- ▶ Clogged slope drains will force water around the pipe and cause slope erosion.
- ▶ Dissipation of high flow velocities at the pipe outlet is required to avoid downstream erosion.
- ▶ Failure can result in flooding and severe erosion.

MAINTENANCE:

- ▶ Structure must be inspected weekly and after storms.
- ▶ Inlet must be free of undercutting and no water should circumvent the entry.
- ▶ Outlet should not produce erosion; velocity dissipators must be maintained.
- ▶ Pipe anchors must be checked to ensure that the pipe remains anchored to the slope.

OBJECTIVES

- Housekeeping Practices
- Contain Waste
- Minimize Disturbed Areas
- Stabilize Disturbed Areas
- Protect Slopes/Channels
- Control Site Perimeter
- Control Internal Erosion



Developed by Salt Lake County

TARGETED POLLUTANTS

- Sediment
- Nutrients
- Toxic Materials
- Oil & Grease
- Floatable Materials
- Other Waste

- IMPLEMENTATION REQUIREMENTS**
- High Impact
 - Medium Impact
 - Low Impact

- Capital Costs
- O&M Costs
- Maintenance
- Training

- High Medium Low

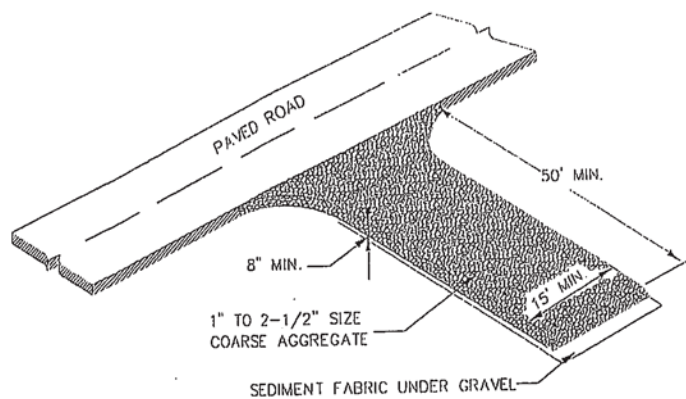

DESCRIPTION:

A stabilized pad of crushed stone located where construction traffic enters or leaves the site from or to paved surface.

APPLICATIONS:

At any point of ingress or egress at a construction site where adjacent traveled way is paved. Generally applies to sites over 2 acres unless special conditions exist.

INSTALLATION/APPLICATION CRITERIA:

- ▶ Clear and grub area and grade to provide maximum slope of 2%.
- ▶ Compact subgrade and place filter fabric if desired (recommended for entrances to remain for more than 3 months).
- ▶ Place coarse aggregate, 1 to 2-1/2 inches in size, to a minimum depth of 8 inches.

LIMITATIONS:

- ▶ Requires periodic top dressing with additional stones.
- ▶ Should be used in conjunction with street sweeping on adjacent public right-of-way.

MAINTENANCE:

- ▶ Inspect daily for loss of gravel or sediment buildup.
- ▶ Inspect adjacent roadway for sediment deposit and clean by sweeping or shoveling.
- ▶ Repair entrance and replace gravel as required to maintain control in good working condition.
- ▶ Expand stabilized area as required to accommodate traffic and prevent erosion at driveways.

OBJECTIVES

- Housekeeping Practices
- Contain Waste
- Minimize Disturbed Areas
- Stabilize Disturbed Areas
- Protect Slopes/Channels
- Control Site Perimeter
- Control Internal Erosion



Developed by Salt Lake County

TARGETED POLLUTANTS

- Sediment
- Nutrients
- Toxic Materials
- Oil & Grease
- Floatable Materials
- Other Waste

- High Impact
- Medium Impact
- Low or Unknown Impact

IMPLEMENTATION REQUIREMENTS

- Capital Costs
- O&M Costs
- Maintenance
- Training

- High
- Medium
- Low

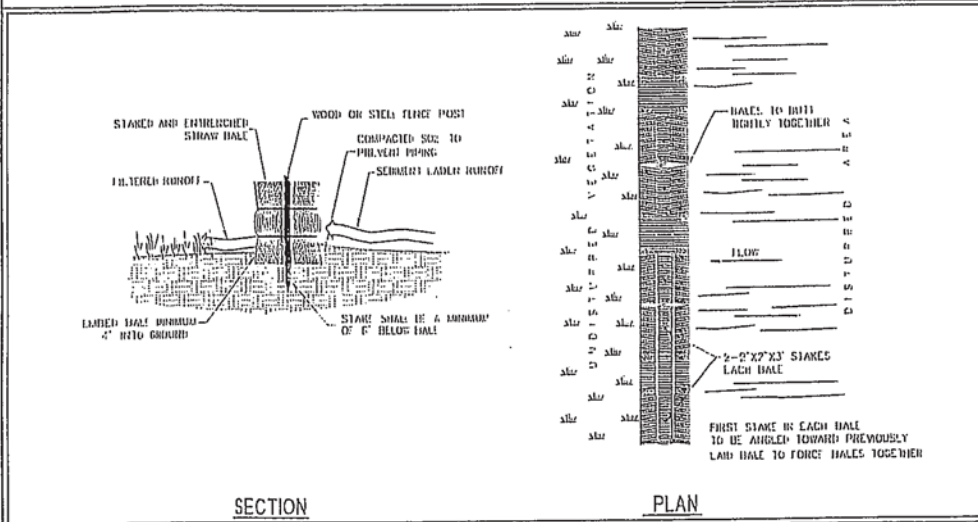

DESCRIPTION:

Temporary sediment barrier consisting of a row of entrenched and anchored straw bales.

APPLICATION:

- ▶ Perimeter Control: place barrier at downgradient limits of disturbance.
- ▶ Sediment barrier: place barrier at toe of slope or soil stockpile.
- ▶ Protection of existing waterways: place barrier at top of stream bank.
- ▶ Inlet Protection.

INSTALLATION/APPLICATION CRITERIA:

- ▶ Excavate a 4-inch minimum deep trench along contour line, i.e. parallel to slope, removing all grass and other material that may allow underflow.
- ▶ Place bales in trench with ends tightly abutting, fill any gaps by wedging loose straw into openings.
- ▶ Anchor each bale with 2 stakes driven flush with the top of the bale.
- ▶ Backfill around bale and compact to prevent piping, backfill on uphill side to be built up 4-inches above ground at the barrier.

LIMITATIONS:

- ▶ Recommended maximum area of 0.5 acre per 100 feet of barrier
- ▶ Recommended maximum upgradient slope length of 150 feet
- ▶ Recommended maximum uphill grade of 2:1 (50%)

MAINTENANCE:

- ▶ Inspect immediately after any rainfall and at least daily during prolonged rainfall.
- ▶ Look for runoff bypassing ends of barriers or undercutting barriers.
- ▶ Repair or replace damaged areas of the barrier and remove accumulated sediment.
- ▶ Realign bales as necessary to provide continuous barrier and fill gaps.
- ▶ Recompact soil around barrier as necessary to prevent piping.

OBJECTIVES

- Housekeeping Practices
- Contain Waste
- Minimize Disturbed Areas
- Stabilize Disturbed Areas
- Protect Slopes/Channels
- Control Site Perimeter
- Control Internal Erosion



Developed by Salt Lake County

TARGETED POLLUTANTS

- Sediment
- Nutrients
- Toxic Materials
- Oil & Grease
- Floatable Materials
- Other Waste

- High Impact
 - Medium Impact
 - Low or Unknown Impact
- IMPLEMENTATION REQUIREMENTS**

- Capital Costs
- O&M Costs
- Maintenance
- Training

High Medium Low



PROGRAM ELEMENTS

- New Development
- Residential
- Commercial Activities
- Industrial Activities
- Municipal Facilities
- Illegal Discharges



Developed by Salt Lake County

DESCRIPTION:

Reduce the discharges of pollutants to stormwater from street surfaces by conducting street cleaning on a regular basis.

APPROACH:

- Prioritize cleaning to use the most sophisticated sweepers, at the highest frequency, and in areas with the highest pollutant loading.
- Restrict street parking prior to and during sweeping.
- Increase sweeping frequency just before the rainy season.
- Proper maintenance and operation of sweepers greatly increase their efficiency.
- Keep accurate operation logs to track programs.
- Reduce the number of parked vehicles using regulations.
- Sweepers effective at removing smaller particles (less than 10 microns) may generate dust that would lead to concerns over worker and public safety.
- Equipment selection can be key for this particular BMP. There are two types used, the mechanical broom sweepers (more effective at picking up large debris and cleaning wet streets), and the vacuum sweepers (more effective at removing fine particles and associated heavy metals). Many communities find it useful to have a compliment of both types in their fleet.

LIMITATIONS:

- Conventional sweepers are not able to remove oil and grease.
- Mechanical sweepers are not effective at removing finer sediments.
- Effectiveness may also be limited by street conditions, traffic congestion, presence of construction projects, climatic conditions and condition of curbs.

MAINTENANCE:

- Replace worn parts as necessary.
- Install main and gutter brooms of the appropriate weight.

TARGETED POLLUTANTS

- Sediment
- Nutrients
- Heavy Metals
- Toxic Materials
- Oxygen Demanding Substances
- Oil & Grease
- Floatable Materials
- Bacteria & Viruses

- High Impact
- Medium Impact
- Low or Unknown Impact

IMPLEMENTATION REQUIREMENTS

- Capital Costs
- O&M Costs
- Regulatory
- Training
- Staffing
- Administrative

- High Medium Low

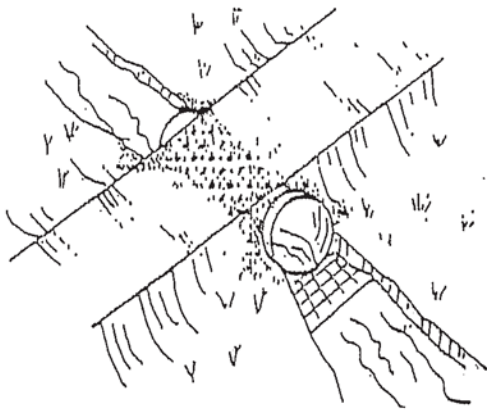

DESCRIPTION:

A temporary access stream crossing is a temporary culvert, ford or bridge placed across a waterway to provide access for construction purposes for a period of less than one year. Temporary access crossings are not intended to be used to maintain traffic for the general public.

APPLICATIONS:

Temporary stream crossings should be installed at all designated crossings of perennial and intermittent streams on the construction site, as well as for dry channels which may be significantly eroded by construction traffic.

INSTALLATION/APPLICATION:

Requires knowledge of stream flows and soil strength and should be designed under the direction of a Utah registered engineer with knowledge of both hydraulics and construction loading requirements for structures.

LIMITATIONS:

- ▶ May be an expensive for a temporary improvement.
- ▶ Requires other BMP's to minimize soil disturbance during installation and removal.
- ▶ Fords should only be used in dry weather.
- ▶ A Stream Alteration Permit may be required, contact the Utah Division of Water Rights before implementation.

MAINTENANCE:

- ▶ Inspect weekly and after each significant rainfall, including assessment of foundations.
- ▶ Periodically remove silt from crossings.
- ▶ Replace lost aggregated from inlets and outlets of culverts.

OBJECTIVES

- Housekeeping Practices
- Contain Waste
- Minimize Disturbed Areas
- Stabilize Disturbed Areas
- Protect Slopes/Channels
- Control Site Perimeter
- Control Internal Erosion



Developed by Salt Lake County

TARGETED POLLUTANTS

- Sediment
- Nutrients
- Toxic Materials
- Oil & Grease
- Floatable Materials
- Other Waste

- High Impact
- Medium Impact
- Low or Unknown Impact

IMPLEMENTATION REQUIREMENTS

- Capital Costs
- O&M Costs
- Maintenance
- Training

- High
- Medium
- Low

BMP: Vehicle And Equipment Cleaning

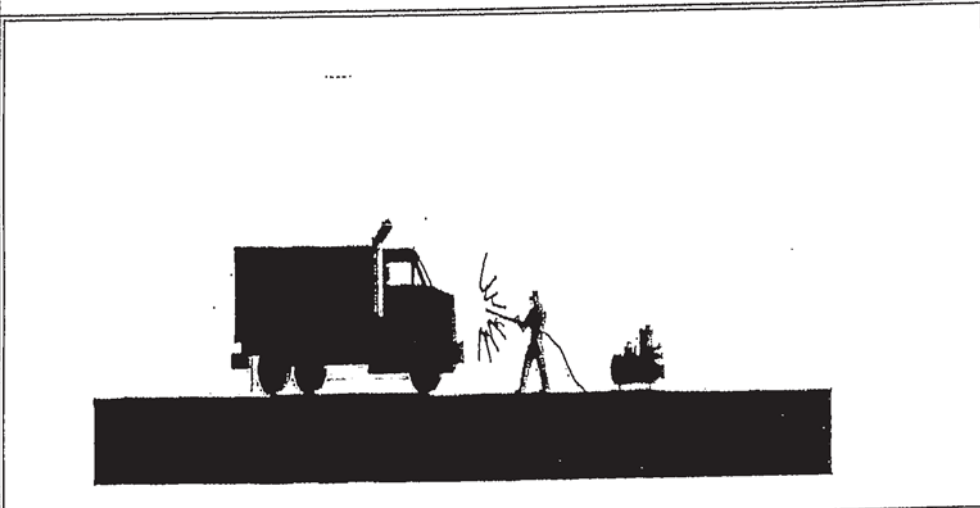

OBJECTIVES

- Housekeeping Practices
- Contain Waste
- Minimize Disturbed Areas
- Stabilize Disturbed Areas
- Protect Slopes/Channels
- Control Site Perimeter
- Control Internal Erosion



DESCRIPTION:

Prevent or reduce the discharge of pollutants to storm water from vehicle and equipment cleaning by using off-site facilities, washing in designated, contained areas only, eliminating discharges to the storm drain by infiltrating or recycling the wash water, and/or training employees and subcontractors.

INSTALLATION/APPLICATION:

- ▶ Use off-site commercial washing businesses as much as possible. Washing vehicles and equipment outdoors or in areas where wash water flows onto paved surfaces or into drainage pathways can pollute storm water. If you wash a large number of vehicles or pieces of equipment, consider conducting this work at an off-site commercial business. These businesses are better equipped to handle and dispose of the wash waters properly. Performing this work off-site can also be economical by eliminating the need for a separate washing operation at your site.
- ▶ If washing must occur on-site, use designated, bermed wash areas to prevent wash water contact with storm water, creeks, rivers, and other water bodies. The wash area can be sloped for wash water collection and subsequent infiltration into the ground.
- ▶ Use as little water as possible to avoid having to install erosion and sediment controls for the wash area. Use phosphate-free biodegradable soaps. Educate employees and subcontractors on pollution prevention measures. Do not permit steam cleaning on-site. Steam cleaning can generate significant pollutant concentrations.

LIMITATIONS:

- ▶ Even phosphate-free, biodegradable soaps have been shown to be toxic to fish before the soap degrades.
- ▶ Sending vehicles/equipment off-site should be done in conjunction with Stabilized Construction Entrance.

MAINTENANCE:

- ▶ Minimal, some berm repair may be necessary.

TARGETED POLLUTANTS

- Sediment
- Nutrients
- Toxic Materials
- Oil & Grease
- Floatable Materials
- Other Waste

- High Impact
- Medium Impact
- IMPLEMENTATION REQUIREMENTS

- Capital Costs
- O&M Costs
- Maintenance
- Training

- High Medium Low